



Optical nodes

Optical nodes

- electronic setting of all parameters
- AGC based on optical input level
- digital indication of optical input level and other parameters on built-in LED display
- switchable ingress blocking filter
- uncooled FP laser diode for CATV return path application
- integrated data transmitter for remote monitoring subsystem "MasterWatch"
- 5 MHz pilot generator inside
- die-cast housing
- connectors:
optical - SC/APC
RF output and test - type F



Technical specifications

T Y P E		OD110	OD110D
Forward path			
Optical wave length		1100-1600 nm	
Optical input level (AGC range)		-7 ...2 dBm	
Noise current density		≤ 7.0 pA/√Hz	
Frequency range** (depending on diplexer)		47/75/87/108-1002 MHz	
Impedance		75 Ω	
Return loss		18 dB/40 MHz-1.5 dB/oct	
Frequency response		± 0.75 dB	
Output level (AGC controlled, 4.9% OMI)		113 dBμV	
Output level (CTB, EN50083-3)		111 dBμV (42 ch.)	
Output level (CSO, EN50083-3)		112 dBμV (42 ch.)	
Interstage attenuator	pr.	0-15 dB by 1 dB step	
Interstage equalizer	pr.	0-15 dB by 1 dB step	
Test point		-20 dB ± 0.7 dB	
Return path			
Laser diode type		FP	
Optical output power*		1/2 mW	
Wave length***		1310 ± 10 nm	
Frequency range** (depending on diplexer)		5-30/55/65/85 MHz	
Ingress blocking filter attenuation	pr.	> 20 dB up to 15 MHz; < 0.5 dB from 20 MHz	
RF input level		75-95 dBμV	
Return path attenuator	pr.	0-25 dB by 1 dB step	
Input return loss		18 dB	
Pilot tone	pr.	5 MHz	
Test point		-20 ± 0.5 dB	
General			
Mains voltage, 50 Hz		187-250 V~	24÷65 V~
Power consumption, max.		15 W	15 W
Current consumption	24 V AC	-	1 A
	42 V AC	-	0.67 A
	65 V AC	-	0.5 A
Operating temperature range		-20° ÷ + 45° C	
Dimensions/Weight (packed)		213x138x76 mm/1.4 kg	

* ordering information:

Type	Laser	Ordering number
OD110R1	1mW FP 1310 nm	02851
OD110R2	2mW FP 1310 nm	02852
OD110DR1	1mW FP 1310 nm, remote powering	02853
OD110DR2	2mW FP 1310 nm, remote powering	02854

** Frequency range

30/47 MHz
55/75 MHz
65/87 MHz
85/108 MHz

Diplexer

pd 06-30
pd 06-55
pd 06-65
pd 06-85

*** DFB 2mW laser diodes for CWDM (1470...1610 nm) band are supplied by special request

pr. software control

Optical nodes

Optical nodes

Structure diagram

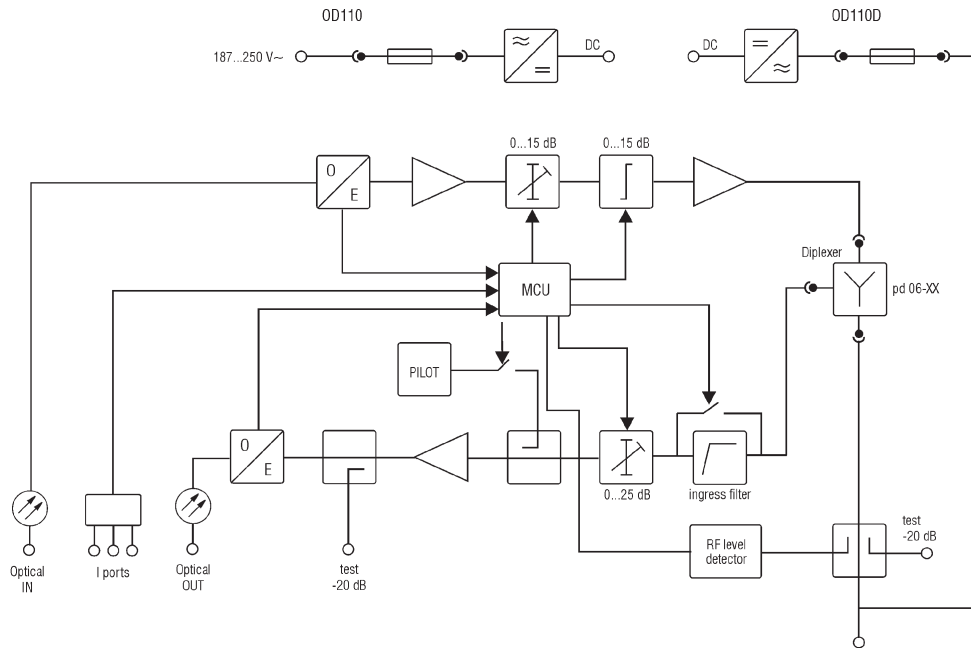

Remotely monitored parameters of the nodes OD110, OD110D using monitoring subsystem "MasterWatch":

- temperature
- power supply DC voltage
- remote power supply AC voltage
- optical input power
- laser bias current
- RF output level
- node status

Remotely monitored ports:

- external alarm circuit port
- UPS status port